

STARTER UNIT SMALL HARDWARE PACKAGE (3400.00057.00)

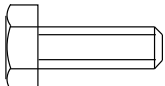

1/4-20x3/4 Bolt
RW# 088780
Qty. 12

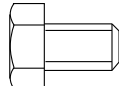

5/16-18x1/2
RW # 0088780
Qty. 8

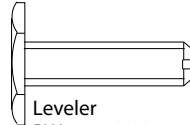

Leveler
RW # 3400.00054.00
Qty. 15



#10x1/2 Tek Screw
RW # 088200
Qty. 8



1/4-20 Flange Nut
RW# 4050.93005.01
Qty. 12

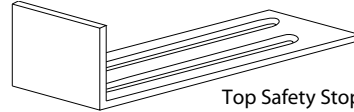

Top Safety Stop
RW# 3400.00016.02
Qty. 2

ADDER UNIT SMALL HARDWARE PACKAGE (3400.00060.00)

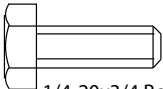

1/4-20x3/4 Bolt
RW# 088780
Qty. 10

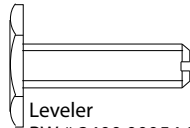

Leveler
RW # 3400.00054.00
Qty. 15



#10x1/2 Tek Screw
RW # 088200
Qty. 8



1/4-20 Flange Nut
RW# 4050.93005.01
Qty. 12

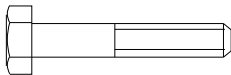

1/4-20x1-1/12 Bolt
RW# 088804
Qty. 2



#10x3/4 Tek Screw
RW# 088616
Qty. 8



1/4-20 Nylok Hex Nut
RW# 4050.95013.04
Qty. 2

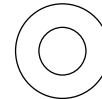

Spacer
RW# 3400.00053.00
Qty. 2

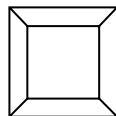

Rubber Bumper
RW# 3400.00070.00
Qty. 2

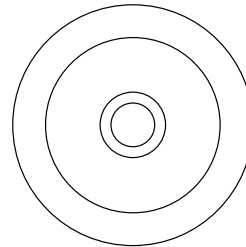

Stabilizer Wheel
RW# 3400.00051.00
Qty. 2

BI-FILE & TRI-FILE PART IDENTIFICATION AND PART NUMBER

Stationary Top Channel
3400.00011.xx *

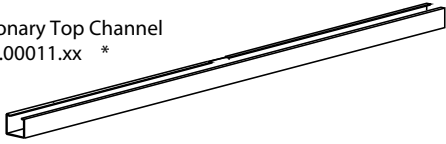

Deck
Part # Varies

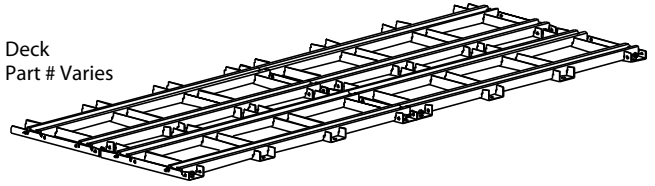

Connector Channel
3400.00012.xx *

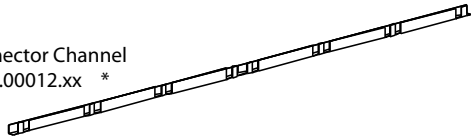

Bi-File Top Stabilizer Bracket Assembly
3400.00014.xx *

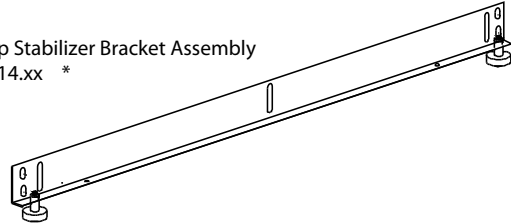

Front Cover
3400.00013.xx *

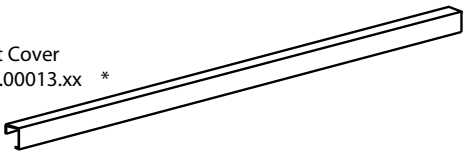

Tri-File Top Stabilizer
3400.00022.xx *

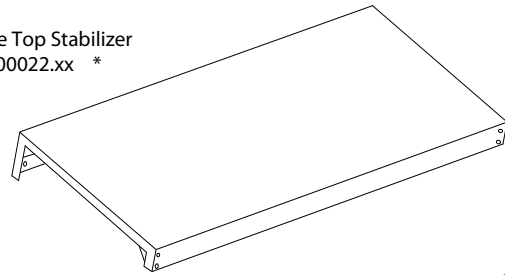

Top Safety Stop
3400.00016.02



Carriage
Part # Varies

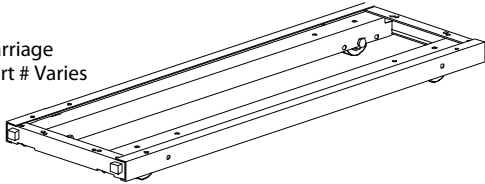

Tri-File Wheel Bracket
3400.00027.xx *

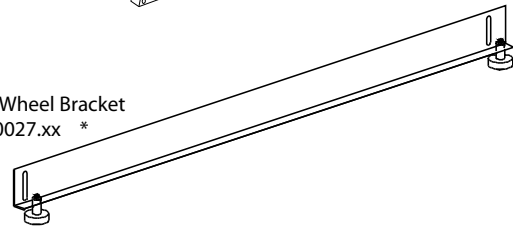

Rear Deck Pan
3400.00040.xx *

Middle Deck Pan
Part # Varies

Joining Deck Pan
3400.00041.xx *

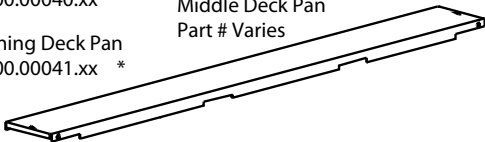

Tri-File Mounting Bracket
TFxxHC00 *

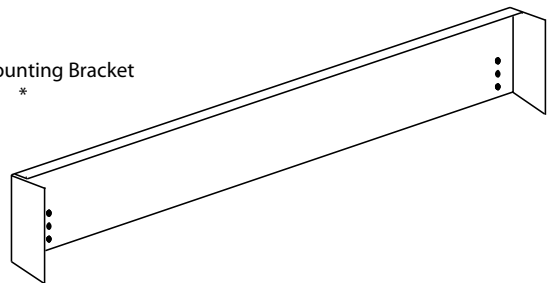

Carriage Safety Stop
3400.00017.01

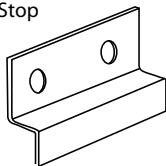

Bi-File Deck End Rail
3400.00018.xx *

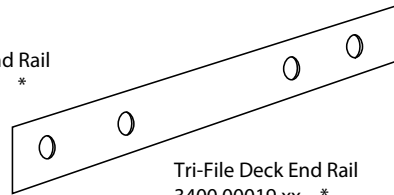

Tri-File Deck End Rail
3400.00019.xx *

* Note: xx denotes dimension

TOOLS REQUIRED

- ☑ 7/16 Wrench
- ☑ Assorted Socket Set
- ☑ Small and Medium Flat Screwdriver
- ☑ Medium Phillips Screwdriver
- ☑ 3/8 Drill
- ☑ 5/16 Metal Drill Bit
- ☑ #2 Phillips Bit
- ☑ Rubber Mallet
- ☑ Hammer
- ☑ 4 Foot Level
- ☑ Pry Bar



Important Notice

All Shelving used on a Side to Side system must have the same overall height. The shelving must also have a minimum of 1- ½ inch of clearance from the floor to the filing surface of the bottom shelves.

B1-FILE ASSEMBLY INSTRUCTIONS

STATIONARY SHELVING ASSEMBLY



Important Notice

All systems will consist of one (1) starter Deck and the required amount of add-on Deck assemblies. The starter Deck assembly contains one (1) section of Deck and hardware. The add-on Deck assembly contains one (1) section of Deck, hardware and one (1) mobile carriage.

- STEP 1 Assemble the rear stationary shelving sections according to the shelving instructions provided. Position the finished stationary shelving on the floor at the area that the system will be installed. It is required that the stationary shelving sections be secured to the wall for stability.
- STEP 2 Attach the Stationary Top Channels to the tops of the stationary shelving sections. Position each channel flush and even with the sides and front of each of the top shelf sections and drill three (3) 5/16 diameter clearance hole in the top shelves. Attach the channel by using three (3) 1/4-20 x 3/4 hex head bolts and secure using the 1/4 - 20 flange nuts. Repeat this step for each rear stationary section. Using the #10 x 1/2 Tek screws, fasten the top shelf to the upright posts. See Figure 1 .

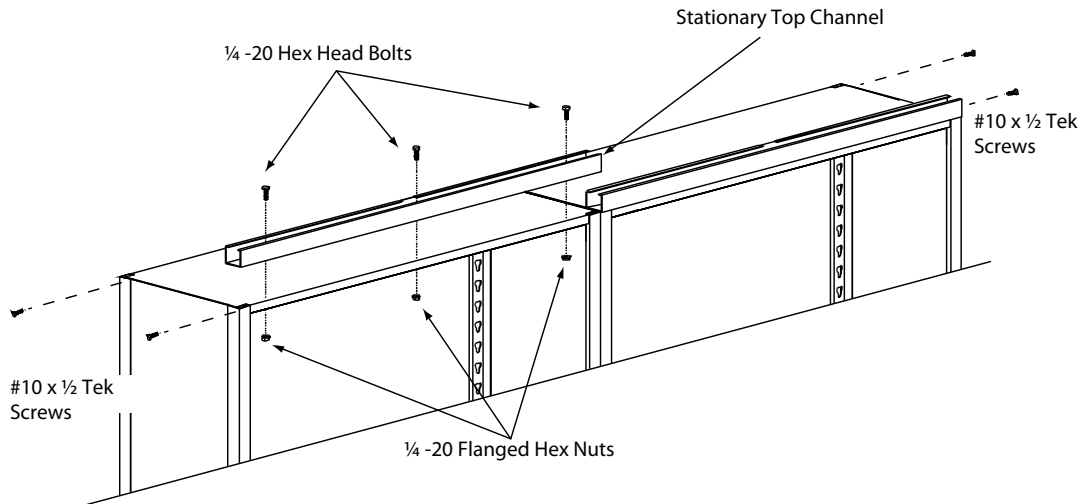

FIGURE 1

DECK ASSEMBLY

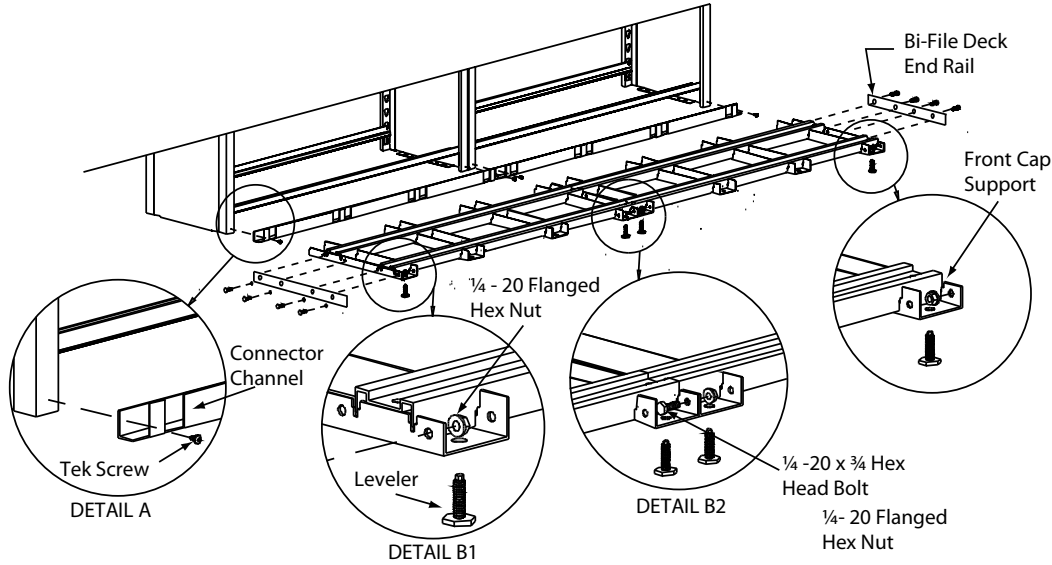

FIGURE 2

- STEP 1 Install Levelers in Deck sections making sure that each one is screwed in and is flush with the bottom of the Deck. See Figure 2, Detail B1
- STEP 2 Position Connector Channels on the front bottom of each stationary base; make sure sides are flush with upright posts. Attach each Connector Channel to the post uprights on the stationary shelving using #10 x 1/2 Tek screws. See Figure 2, Detail A
- STEP 3 Attach the assembled Deck sections to the Connector Channels. The Deck assembly will have corresponding slots which will secure to the Connector Channel. See Figure 2
- STEP 4 Join Decks together by using 1/4-20 x 3/4 hex head bolts and flange nuts. The number of fasteners will vary due to system size. The Deck sections will have corresponding holes for attaching side to side. See Figure 2, Detail B2 .
- STEP 5 Secure Bi-File Deck End Rails to both sides of the Deck assemblies by using four (4) 1/4-20 x 3/4 hex head bolts and flange nuts. See Figure 2 .
- STEP 6 Level the Deck assembly. Determine highest point on the Deck assembly. Start from this highest point and move out, level the Deck by adjusting the appropriate Leveler.



Important Notice

For systems to function properly all Decks must be level from left-to-right, front-to-back, and Deck to Deck. All Levelers must be in contact with the floor. Use Levelers to make sure Deck rails from each section line up with each other.

DECK PAN ASSEMBLY

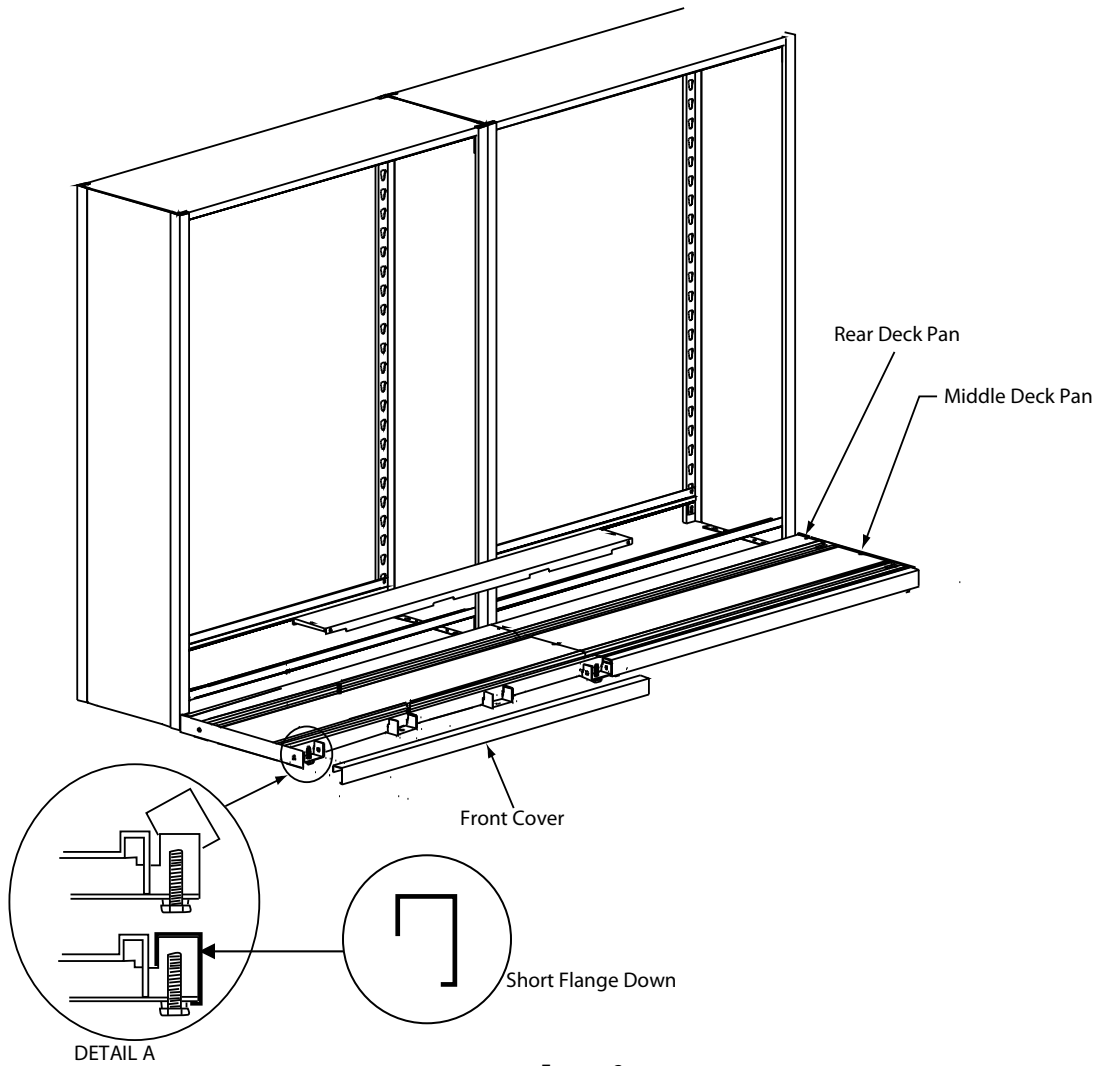

FIGURE 3

- STEP 1** Install the Rear Deck Pans, the Deck pan sections interlock with the Deck assembly. The Rear Deck Pans should be flush with the top of the Deck when properly installed. See Figure 3 .
- STEP 2** Install the Middle Deck Pans, the Deck pan sections interlock with the Deck assembly. The Middle Deck Pans should be flush with the top of the Deck when properly installed. See Figure 3 .
- STEP 3** Attach the Front Cover to each Deck section by snapping the Front Cover over the front Deck cross-mem bers. Make sure that the short flange is down. See Figure 3, Detail A . Repeat this step for remaining Deck sections.

CARRIAGE ASSEMBLY

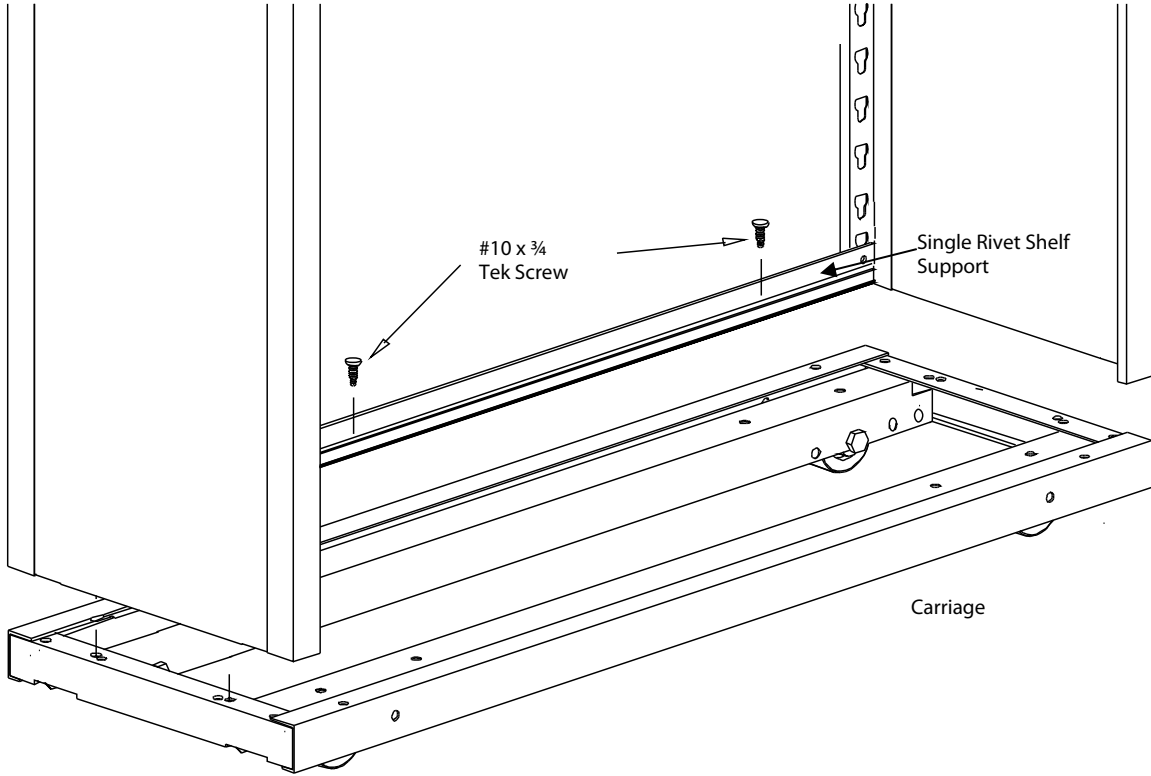
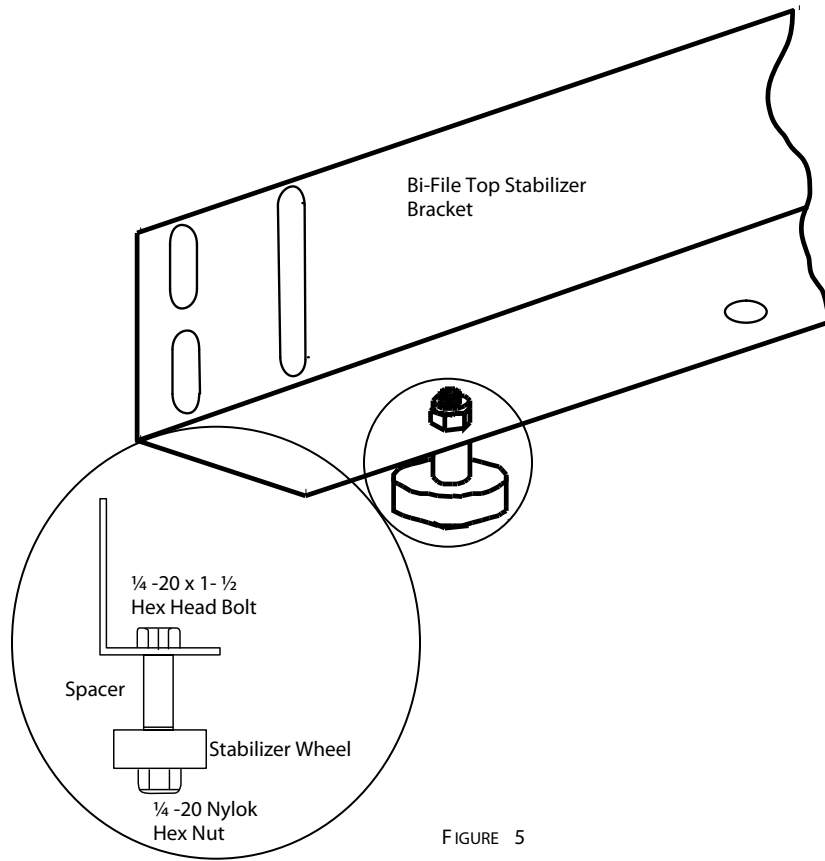

FIGURE 4

STEP 1 Assemble shelving for the mobile units per the shelving instructions. Single rivet shelf supports must be used in the bottom position. Do not install individual shelving at this point. Use #10 x 3/4 Tek screws and attach the bottom single rivet shelf supports to the carriage. See Figure 4 .

BI-FILE TOP STABILIZER BRACKET ASSEMBLY



STEP 1 Assemble the Stabilizer Wheel to the Bi-File Top Stabilizer Bracket at both ends of this bracket, using the outer holes. Use the following hardware: two (2) 1/4 -20 x 1- 1/2 hex head bolts, two (2) 1/4 -20 nylok hex nuts, two (2) Spacers, and two (2) Stabilizer Wheels. See Figure 5 .

BI-FILE TOP STABILIZER BRACKET ASSEMBLY INSTALLATION PROCEDURE

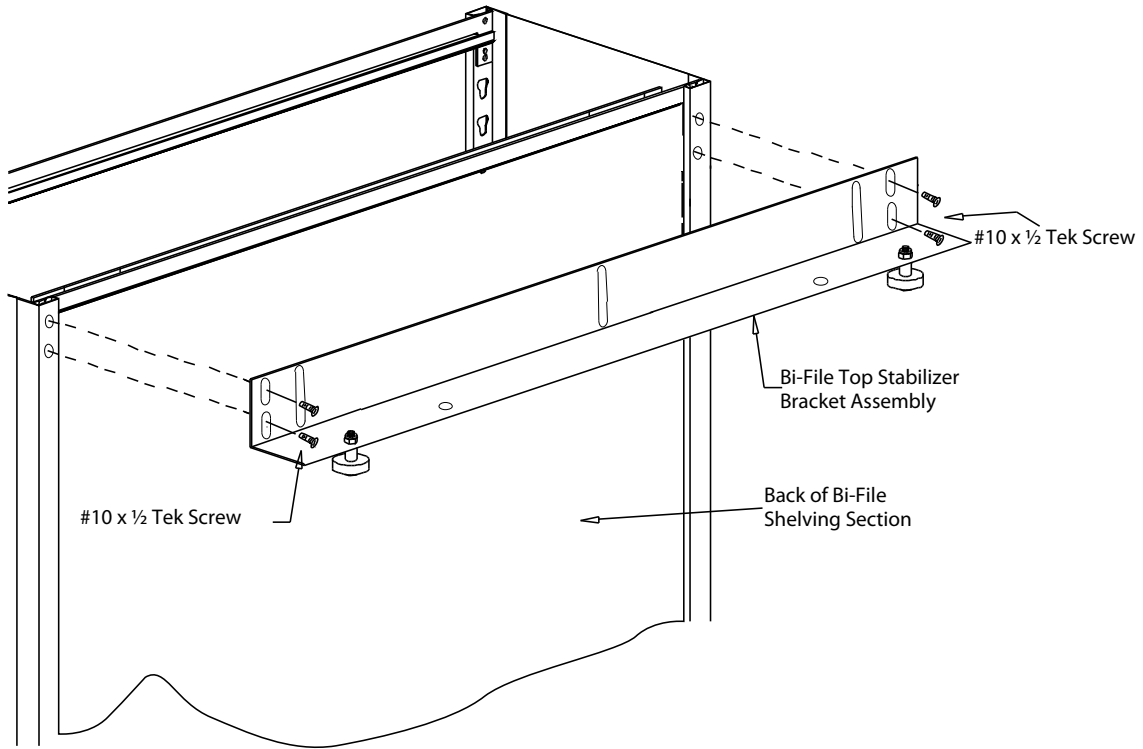

FIGURE 6

STEP 1 Fasten the Bi-File Top Stabilizer Bracket assembly to the top back of each Bi-File Shelving sections by using four (4) #10 x 1/2 Tek screws. See Figure 6 .



Important Notice

It is required that the Bi-File Top Stabilizer Bracket be installed properly. If it is not installed the Side to Side system will become dangerously unstable.

CARRIAGE ASSEMBLY

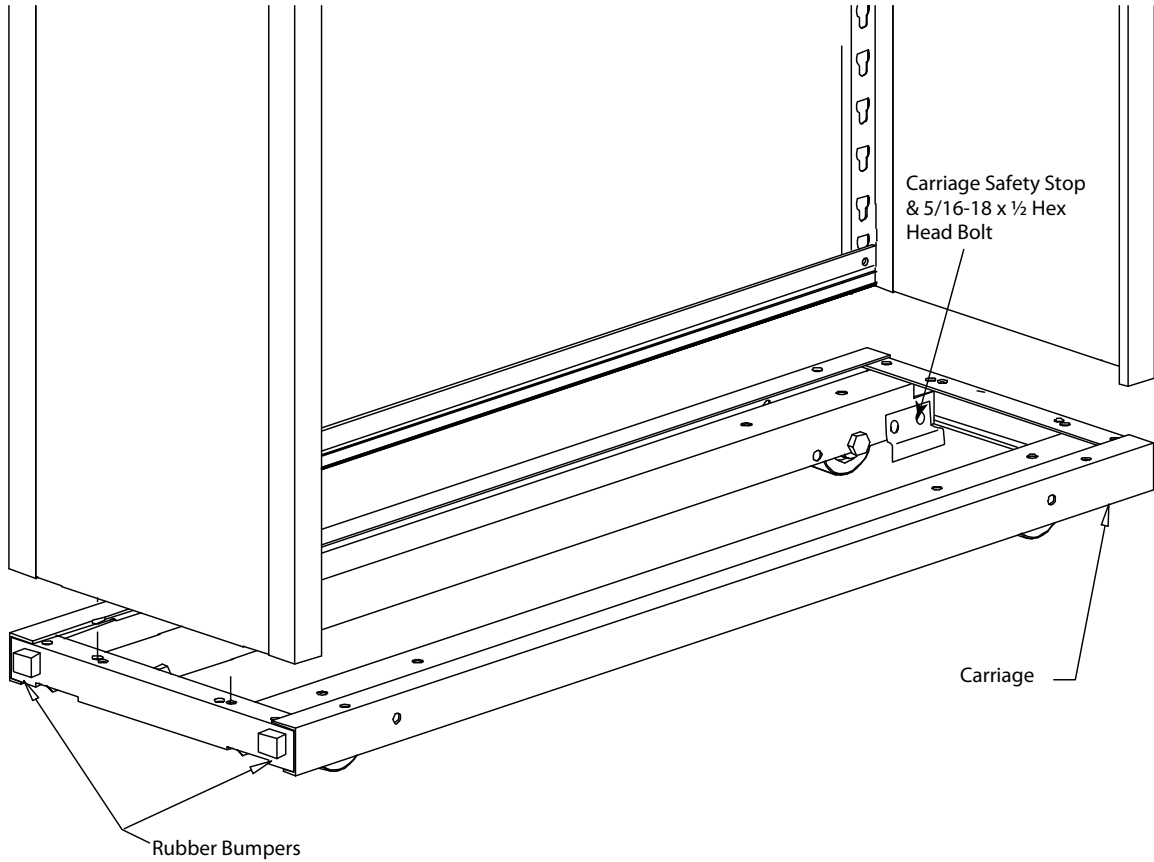

FIGURE 7

- STEP 1 Install Carriage(s) onto Deck assembly. Install the Carriage Safety Stops to the outside of the wheel's main beam(s). See Figure 7 . Attach the Carriage Safety Stops with two (2) 5/16–18 x 1/2 hex head bolts.
- STEP 2 Peel protective backing on adhesive on two (2) Rubber Bumper squares. Adhere to both sides of Carriage at the bottom. See Figure 7 .
- STEP 3 Install the shelves.
- STEP 4 Adjust the Bi-File Top Stabilizer Bracket so the Stabilizer Wheels are in the middle of the Stationary Top Channel.

TOP SAFETY STOP

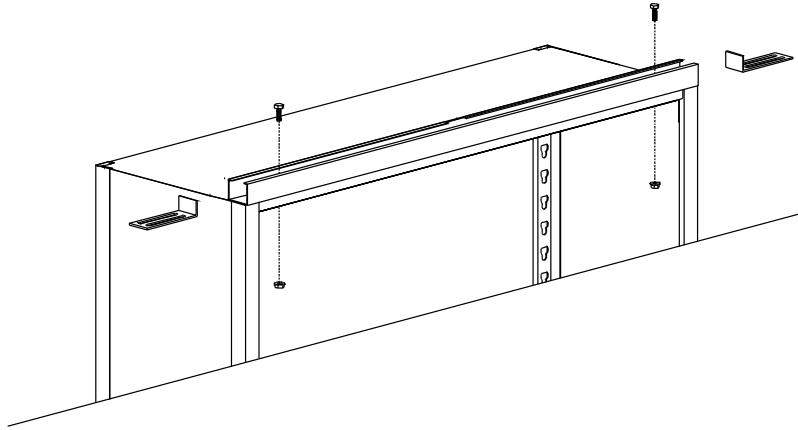

FIGURE 8

STEP 1.1 If the system is a single static carriage application; remove one (1) ¼ -20 x ¾ hex head bolt from the left and right side of the Stationary Top Channel. Insert Top Safety Stops to each end of the Stationary Top Channel. Re-install and tighten the ¼ -20 x ¾ hex head bolts. See Figure 8 .

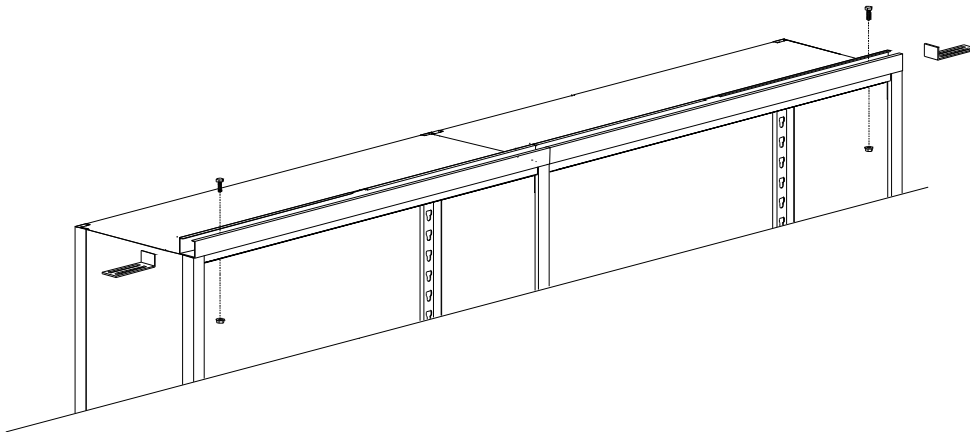

FIGURE 9

STEP 1.2 If the system has more than one static carriage, remove one (1) ¼ -20 x ¾ hex head bolts from the far left and far right sides of the Stationary Top Channels. Insert Top Safety Stops to each end of the Stationary Top Channels. Re-install and tighten the ¼ -20 x ¾ hex head bolts. See Figure 9.

STEP 2 Peel protective backing on adhesive on two (2) Rubber Bumper squares. Adhere to Bumpers to each Side to Side Carriage. One pair of Bumpers is needed for between Carriages.

SAFETY PRECAUTIONS

- STEP 1 Read through the instructions again to insure that all steps are complete.
- STEP 2 Re-check and tighten any loose nuts or/and bolts.
- STEP 3 Check that all Stationary Top Channels are secured to the tops of the Stationary Sections.
- STEP 4 Check that all Stationary Sections have their top shelves properly secured.
- STEP 5 Check that all Rubber Bumpers installed properly.

PROPER METHOD FOR LOADING FILES

Loading a Side to Side System in the correct manner is very important. The way in which the files are loaded balances the paper weight load throughout the entire system and minimizes the need to move the Carriage sections every time the system is used. Careful planning of this phase of the installation will make filing and retrieval more efficient. It is recommended the system be loaded first from the left rear section followed by the first Carriage section of the left side. See Figure 10 .

Repeat loading from rear to front until complete.

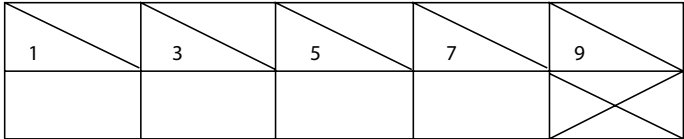

FIGURE 10

RE-LEVELING THE SIDE-TO-SIDE SYSTEM

If the Carriages sections begin to move or creep on their own, when loaded, the system will need to be re-leveled. While this problem is more annoying than dangerous, it may be corrected by re-leveling the Deck Assembly. The Side-to-Side system has been designed so that the Deck Pans can be easily removed for accessing the Levelers.

To remove a Deck Pan, move the Carriage section to one side. Then insert a slotted screwdriver into the slot provided on the Deck Pan, and pull up to remove it.

Re-adjust the Levelers by turning them one-quarter ($1/4$) turn at a time either raising or lowering the Deck assembly to the desired height to stop unwanted movement.

Important Notice

It is very important that all Levelers maintain constant contact with the floor.

When this adjustment has been completed, re-install the Deck Pans that have been removed.