

FRANKLIN MLLS LOCKING STACKABLE ASSEMBLY INSTRUCTION SHEET

Open boxes and check to make sure you have all pieces needed before starting to assemble
*****PLEASE READ ENTIRE ASSEMBLY SHEET BEFORE STARTING*****

TOOLS NEEDED FOR ASSEMBLY: Hammer, Level & 7/32" Nut Driver

TOOLS PROVIDED (Starter Units only) in plastic hardware bag: 3/32" Allen wrench, 4 Drive Rivets and 2 Allen screws (and one spare).

TOOLS PROVIDED (Add-on Units only) in plastic hardware bag: 3/32" Allen wrench, 2 Allen screws & 8 Drive Rivets.

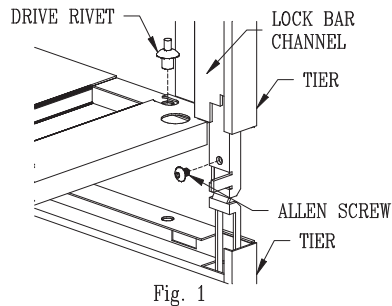
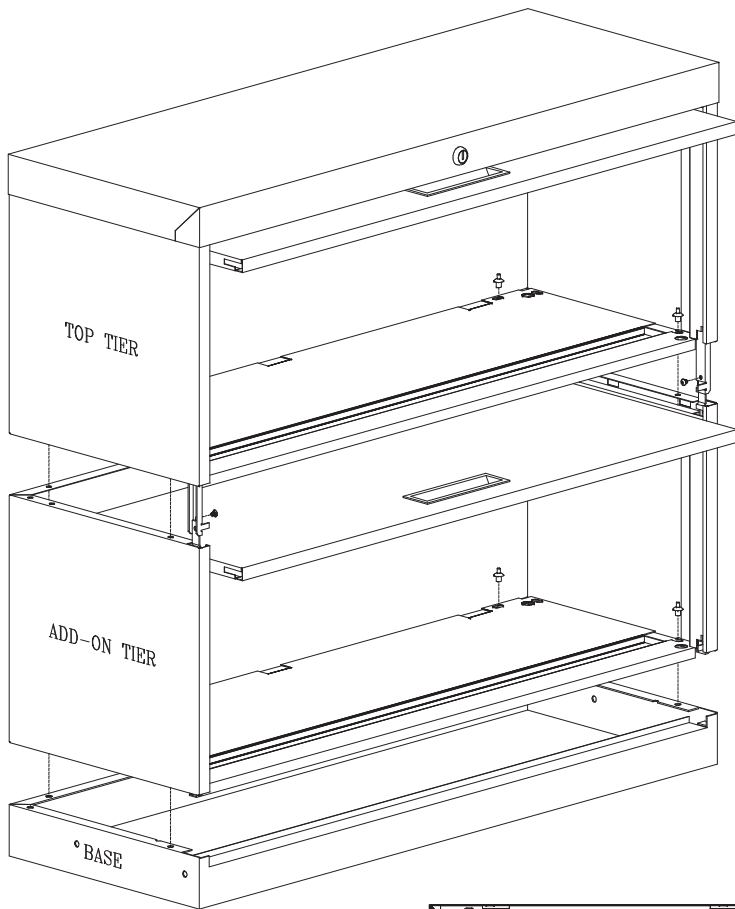

Fig. 1

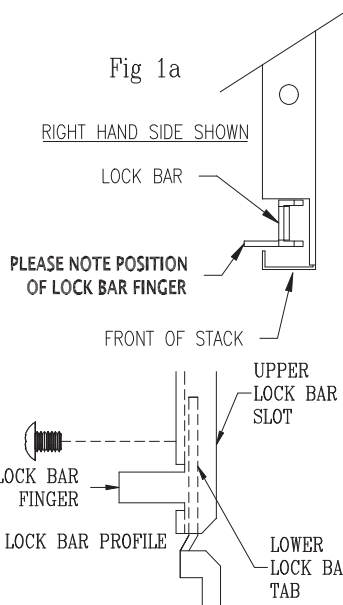

Fig 1a

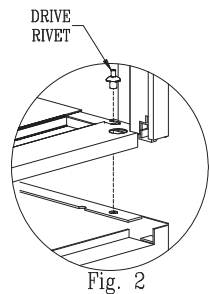

Fig. 2

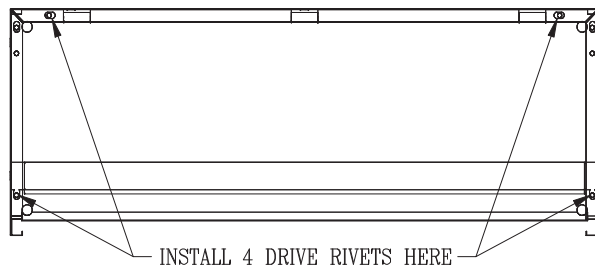
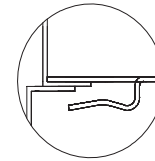

Fig. 3



INTERLOCKING TABS
Fig. 4

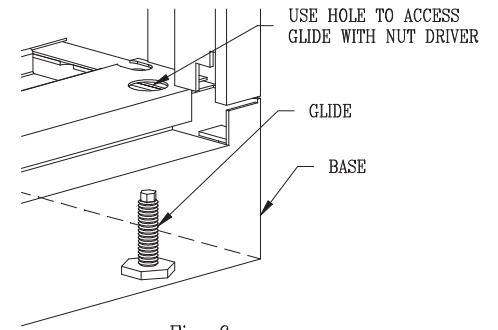

Fig. 6

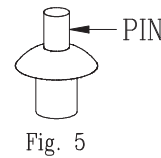
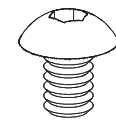

Fig. 5

DRIVE RIVET



ALLEN SCREW

A.)

- 1 As you face the base, make sure the side with the lower lip is in the front; lip with holes in rear.
- 2 Insert the two (2) lock bars (see Fig. 1a) into the lock bar channels going from the underside of the tier up. Make sure lock bar finger faces toward front of tier (Fig. 1).
- 3 Position tier on top of base sliding tier towards the back. Be sure that the three INTERLOCKING TABS on the bottom of the tier hook under the rear lip of the base (Fig. 4). All sides must be flush. Be careful not to let lock bars fall out of lock bar channels.
- 4 Align the small holes in the tier bottom with the corresponding holes in the base and insert **FOUR ONLY** drive rivets (pin side up) in the holes using the hole pattern shown in Fig. 3. Use a hammer to drive rivet pins into the body of the rivets until pins are flush with the

B.)

- 1 Remove next add-on tier and hardware kit from shipping box. From bottom of tier insert the two (2) lock bars into the lock bar channels as done previously in step A2. Carefully position tier on top of previous tier. Slide tier towards back of unit so the three INTERLOCKING TABS on the bottom of the tier hook under the rear lip of the tier below.
- 2 Lift up the front of the add-on tier and position it so that the lower lock bar tab fits inside the upper lock bar slot (Fig. 1) on both left and right sides. Fasten lock bars together using the Allen screws and Allen wrench provided in the hardware bag (Figs. 1).
- 3 Insert rivets in holes as described in instructions A3 above.
- 4 Repeat the above steps until all tiers are assembled. The tier with the lock (in Starter Unit carton) must be assembled as the top or last tier.

C.)

- 1 For doors to operate smoothly, Stak-N-Lok[®] tier sections must be leveled. Place level on top of top most tier. Using a 7/32" nut driver, raise or lower the leveling glides (see Fig. 6) until the unit is level front-to-back and side-to-side.

To add tiers to existing units, see back of this sheet.

For assembly assistance or missing parts, contact Customer Service.

assembly instructions for 2 piece units

******IMPORTANT*** Please read
entire assembly sheet before
assembly***

Tools required: Allen key (provided), Hammer

- 1.) 7 openings high units will now be shipped in two pieces to reduce the chance of damage during shipping.
- 2.) Remove packaging materials from bottom half of unit. Place bottom half of unit in the desired location.
- 3.) Remove packaging materials from top half of unit. Carefully place top half of unit on bottom half of unit making sure that the clips on the top half slide over the flange on the bottom half. You may want to have someone help with lifting since unit is bulky.
- 4.) Connect lock bars together using screws and Allen key (2 sides). **DO NOT** over tighten.
- 5.) Finally, place 4 drive rivets into holes on inside of unit (2 in front holes and 2 in rear holes). Using a hammer, drive rivet pins into the body of the rivets until pins are flush with the top of the rivet head.

